



# E-Z PIPECUT MANUAL

*Manual Chain Driven portable oxy-fuel cutting machine*

TAG's E-Z Pipecut portable oxy-fuel cutting and bevelling chain driven machines are the economical solution for cutting and bevelling pipe from 5 - 50mm upwards. The E-Z Pipecut is small and compact, strong and reliable, used by contractors, welders and pipe fitters, equally at home, on-site or in the workshop.

The TAG E-Z Pipecut portable oxy-fuel cutting and bevelling machine is a straight forward hand operated compact chain - driven pipe cutting machine that provides a smooth, accurate cutting action by incorporating a low gear ratio and worm wheel drive.

The unit also features a quick release clutch. This allows the operator to disengage the chain from the drive cog for rapid set up and positioning.

The bevelling head angle (45gr) can be set quickly and accurately by scale on a rack and pinion.

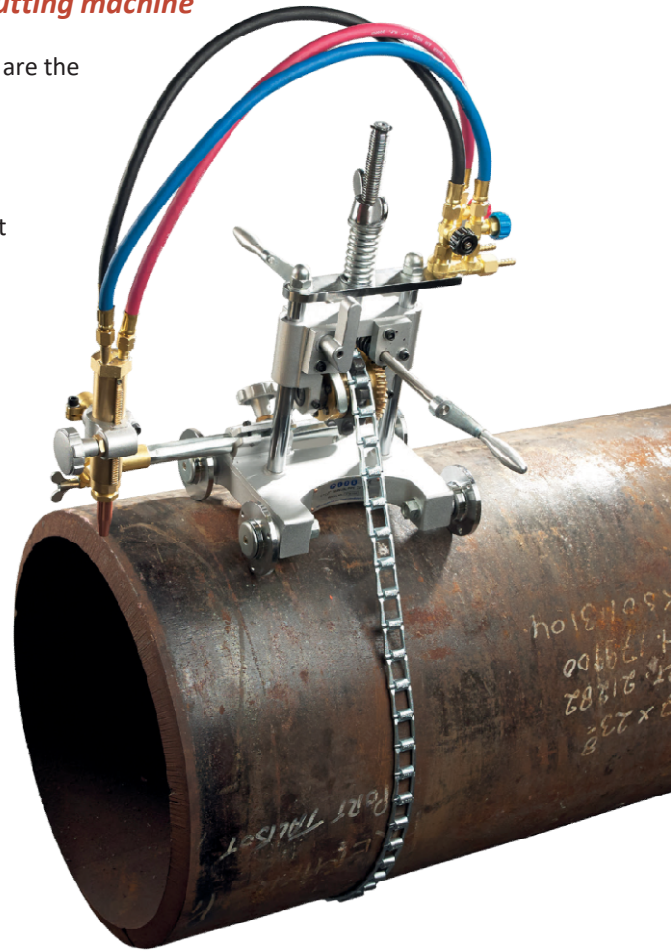

### Guide Band

For guaranteed square cuts and bevels on pipe diameters larger than 600mm we recommend the selection of the optional guide band system to suit the relevant pipe size(s).

## TECHNICAL SPECIFICATION

Part No	EZPCM
Power Supply	Manual driven unit
Pipe Diameter	up to 600mm (in standard configuration)
Wall Thickness	5 - 50mm
Torch	Universal nozzle-mix torch suitable for all nozzle-mix cutting nozzle
Cut/Bevel Angle	Variable up to 45 Degree
Vertical Torch +/-	50mm
Lateral Torch +/-	100mm
Track Width	230mm
Weight	8.5kg / 18.7lbs
Dimensions	350(l) x 420(w) x 550 (h)mm

### Scope of Delivery

Cutting machine E-Z Pipecut Manual  
 Cutting nozzles (5 - 30mm)  
 Standard chain for cutting pipe diameter of 114 - 600mm  
 Operation Instructions

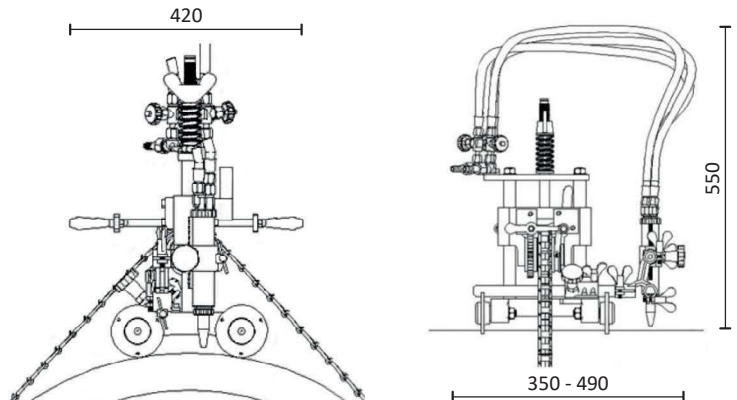

**ARC-TECH**  
 Sol. Ind. y Soldadura 2008, S.L.U.  
 C/ Rio Tajo, Nave 1  
 Santa Olalla 45530 - TOLEDO  
 Tf. +34 925 797 688 - FAX +34 925 797 064

