

■ MINI SPIDER | FILLET WELDING TRACTOR

The Mini Spider is a battery-powered welding tractor designed to produce continuous fillet welds using MIG/MAG torches. The torch can be easily swapped from one side of Mini Spider to another.

4-wheel drive system with magnetic traction and a feedback loop provides highly efficient speed stabilization. Constant, continuous and repeatable travel speed enables weld bead geometry that is exact to the required specifications, thus reducing costly over welding and substantially decreasing filler metal usage.

An optional power supply can be used to plug the tractor into a 110–240 V power source.

■ Features and benefits:

- Compact and lightweight design to weld in narrow spaces
- Convenient 18 V DC battery supply (the same battery for both Mini Spider and Gecko Battery)
- Torch placement on either side
- Welding edge to edge
- Closed-loop speed control system based on electric motor with encoder – ensures increased speed accuracy
- Consistent heat input reduces distortion
- Reduces wasted filler metal – eliminates over welding
- Digital LED display for presetting of travel speed and diagnostic messages
- Low-battery indicator
- Built-in guide rollers



Optional 110–240 V power supply



Welding edge to edge

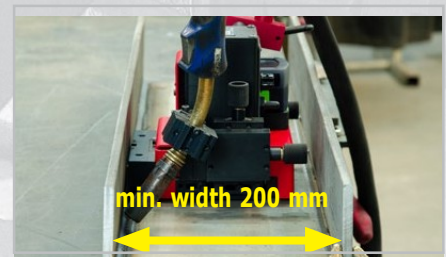

Welding in narrow spaces

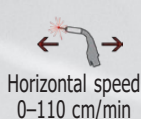

MINI SPIDER Technical Specification

Voltage	18 V DC, 5.2 Ah 1~ 110–240 V, 50–60 Hz (option)
Power	25 W
Welding position (according to EN ISO 6947 and AWS/ASME)	PB / 2F PD / 4F
Torch diameter	16–22 mm (0.63–0.87")
Min. workpiece thickness	4 mm (0.16")
Ground clearance	4 mm (0.16")
Horizontal pulling force	150 N
Vertical pulling force	100 N
Horizontal speed *	0–110 cm/min (0–43.3 in/min)
Vertical speed *	0–100 cm/min (0–39.4 in/min)
Weight (w/o battery)	7.6 kg (22 lbs)
Product code	WOZ-0655-10-00-00-0

* With battery fully charged

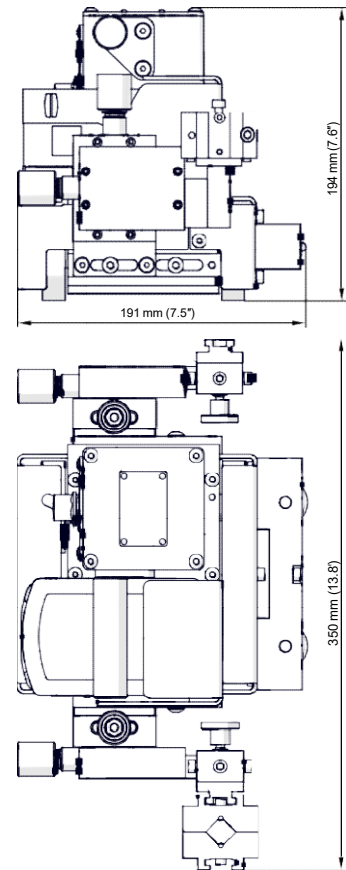

Standard accessories:



Torch holder
ZCS-0270-42-00-00-0



5.2 Ah Battery
AKM-000086



Power supply
ZSL-0526-20-00-00-0



Cable anchor
UCW-0655-08-00-00-0



Battery charger
LDW-000006 (220–240 V, 50/60 Hz)
LDW-000007 (120 V, 60 Hz)



Power cord 3 m (10 ft)
PWD-0466-18-00-00-0 (230 V CEE)
PWD-0466-16-00-00-0 (115 V USA)
PWD-0466-23-00-00-0 (115 V UK)



Torch placement on either side



Standard shipping set:

- Mini Spider tractor
- Foam-filled cardboard box
- Battery
- 4 mm hex wrench
- 3 mm hex wrench
- Operator's Manual



Auxiliary magnet blocks
ZST-0655-09-00-00-0



American Welding Society
Supporting Company Member



www.solysol.com.es

info@solysol.com.es



Cert. N. E5058359-B-1