



E-Z PIPECUT AUTO

Automatic Chain Driven portable oxy-fuel cutting machine

TAG's E-Z Pipecut is also available as an automatic motor driven model. Driven around the pipe with a with speed adjustable remote control, once the speed is set correctly to the wall thickness of the pipe the E-Z Pipecut Auto portable oxy-fuel cutting machine will cut and bevel the pipe without the need for intervention from the operator.

The E-Z Pipecut Auto portable oxy-fuel cutting machine can also be used for cutting exotic materials such as stainless steel, by converting from oxy-fuel to a plasma system (plasma torch holder available on request).

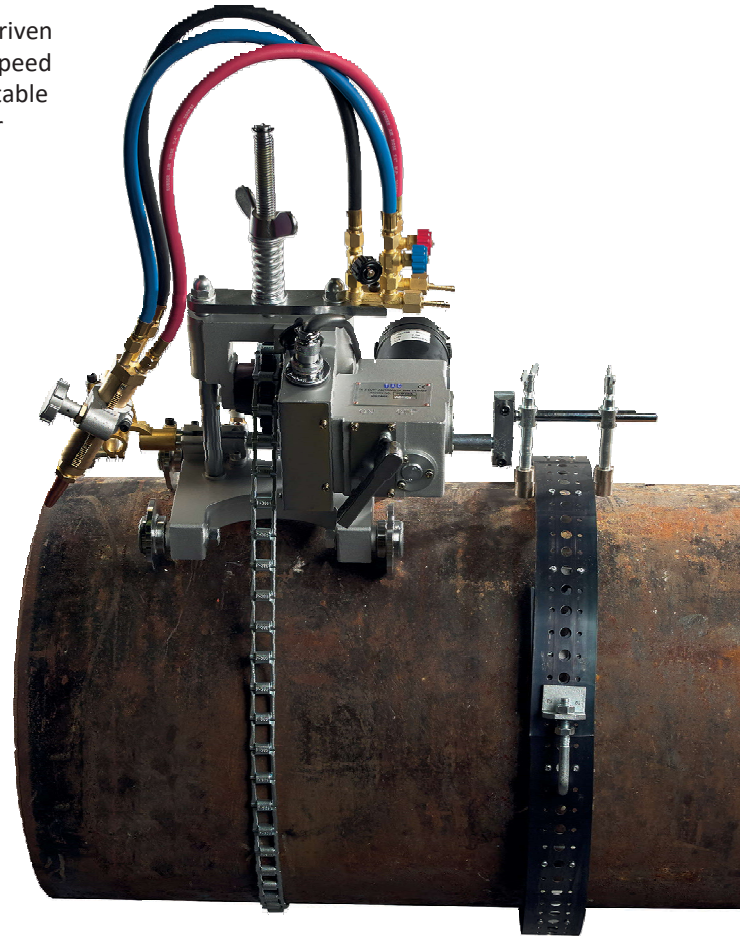

Guide Band

For guaranteed square cuts and bevels on pipe diameters larger than 600mm we recommend the selection of the optional guide band system to suit the relevant pipe size(s).

TECHNICAL SPECIFICATION

Part No	EZPCA1: 110v / EZPCA2: 220v
Power Supply	230v / 110v / 50 - 60Hz
Pipe Diameter	Up to 600mm (in standard configuration)
Wall Thickness	5 - 50mm
Torch	Universal nozzle-mix torch suitable for all nozzle-mix cutting nozzle
Cut/Bevel Angle	Variable up to 45 Degree
Vertical Torch +/-	50mm
Lateral Torch +/-	100mm
Track Width	230mm
Cutting Speed	50 - 1150mm/min
Weight	16kg / 36lbs
Dimensions	420(l) x 280(w) x 550 (h)mm

Scope of Delivery

Pipe cutting machine E-Z Pipecut Auto
 Standard chain for cutting pipe diameter of 114 - 600mm
 Cutting nozzle (5 - 30mm)
 Connecting lead (5m)
 Remote control
 Transformer 110v - 220v
 Operation Instructions

Remote Control

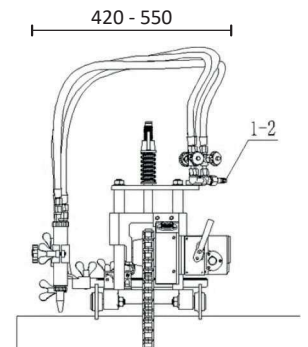
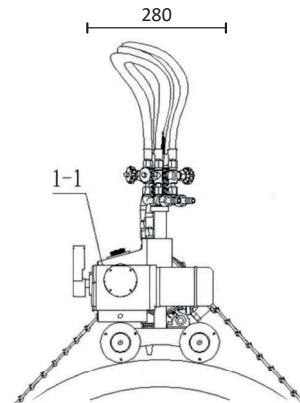

Sol. Ind. y Soldadura 2008, S.L.U.
 C/ Rio Tejo, Nave 1
 Santa Olalla 45530 - TOLEDO
 Tl. +34 925 797 688 - FAX +34 925 797 064



American Welding Society
 INTERNATIONAL AGENT